

**WIRING DIAGRAMS**  
**Article Text**  
1988 Volkswagen Golf  
For <http://volkswagen.msk.ru>  
Copyright © 1998 Mitchell Repair Information Company, LLC  
Monday, January 29, 2001 12:27AM

**ARTICLE BEGINNING**

1988 Wiring Diagrams  
Volkswagen

Golf, GTI

**COMPONENT LOCATION MENU**

COMPONENT LOCATIONS TABLE

Component	Figure No. (Location)
A/C Compressor Clutch .....	2 (D 6)
A/C Ctrl Head .....	3 (E 11)
A/C Low Pres Sw .....	2 (E 4)
A/C Thermostat .....	2 (D 5)
Alternator .....	1 (B 3)
Back-Up Lt Sw (M/T) .....	1 (C 3)
Battery .....	1 (A 1-2)
Beam Sel Sw .....	5 (C 16)
Cig Ltr .....	6 (D 23)
Cig Ltr Lt (GTI) .....	6 (D 23)
Cold Start Valve .....	1 (C 3)
Cruise Ctrl System .....	3 (D-E 8-9)
Circuit Breaker .....	4 (A 13)
Defog Grid .....	7 (A 24-25)
Defog Sw .....	5 (E 19)
Diagnostic Sw .....	3 (B 11)
Digifant Ctrl Unit .....	3 (A 9-10)
Dir Sw .....	5 (E 18)
Dome Lt .....	6 (C 23)
Door Locking Sw .....	7 (D 24)
Door Sws .....	6 (C-D 22)
Flasher Rly .....	5 (D 16)
Fresh Air Ctrl Systems .....	3 (D 11)
Fuel Injection Ctrl Unit (GTI) .....	2 (A 5-6)
Fuel Pump Rly .....	3 (C 8)
Fuel Pump Rly (GTI) .....	2 (D 7)
Fuel Tank Unit & Fuel Pump .....	7 (E 24)
Fus Links .....	1 (A 2)
Fuse Panel .....	4 (B-C 12-15)
Glove Compt Lt & Sw .....	6 (D-E 23)
Hazard Sw .....	5 (E 16)
Headlight Sw .....	5 (B-C 16)
Horn System .....	1 (C 1-2)
Ignition Coil .....	3 (A 11)
Ignition Coil (GTI) .....	2 (C 4)
Ignition Sw .....	5 (A 16)
Instrument Cluster .....	6 (A-E 20)
Load Reduction Rly .....	5 (B 16)
Low Coolant Rly .....	1 (E 3)

## WIRING DIAGRAMS

### Article Text (p. 2)

1988 Volkswagen Golf

For <http://volkswagen.msk.ru>

Copyright © 1998 Mitchell Repair Information Company, LLC

Monday, January 29, 2001 12:27AM

Neutral Safety Back-Up Light Switch (A/T) .....	1 (B 3)
Oil Pres Sws .....	6 (C-D 21)
OXS Mileage Counter .....	6 (D 21)
Passive Restraint Rly .....	6 (A 23)
Power Mirror System .....	7 (A-B 24-26)
Power Window System .....	7 (B-C 24-25)
Power Supply Rly .....	3 (C 11)
Rad Cooling Fan .....	2 (E 5-6)
Rad Cooling Fan System (GTI W/O A/C) .....	1 (D-E 3)
Rad Fan After Run Rly (Golf Gl & GT) .....	2 (E 7)
Rad Fan Rly (Low Speed) .....	2 (D 4)
Rad Fan Rly (Hi Speed) .....	2 (E 4)
Rad Fan Thermo Sw .....	2 (E 5-6)
Relay Bridge Block .....	6 (A 22)
Relay Panel .....	4 (D-E 12-15)
Seat Belt/Brake Warn Ind .....	6 (B-C 23)
Seat Belt Interlock Rly .....	6 (A-B 23)
Starter .....	1 (A 3)
Stop Lt Sw .....	4 (C-D 12)
Trunk Lt & Sw .....	7 (D-E 24)
Vanity Mirror Lt & Sw .....	6 (D 23)
Wiper/Washer System .....	5 (A-D 19)

---

## WIRING DIAGRAMS



**WIRING DIAGRAMS**  
**Article Text (p. 4)**  
 1988 Volkswagen Golf  
 For <http://volkswagen.msk.ru>  
 Copyright © 1998 Mitchell Repair Information Company, LLC  
 Monday, January 29, 2001 12:27AM

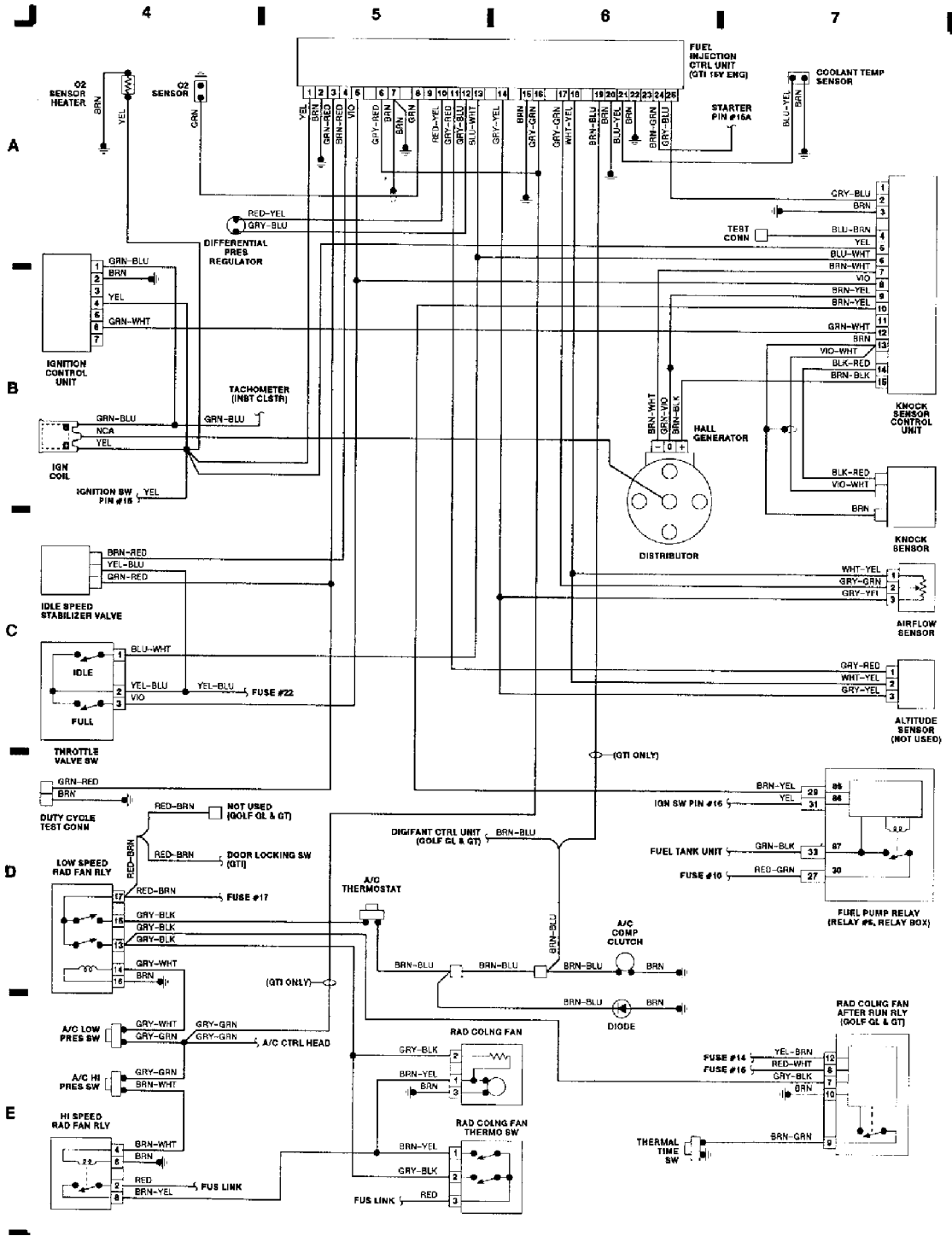

Fig. 2: Computer Engine Control (GTI 16-Valve Engine)

**WIRING DIAGRAMS**  
**Article Text (p. 5)**  
 1988 Volkswagen Golf  
 For <http://volkswagen.msk.ru>  
 Copyright © 1998 Mitchell Repair Information Company, LLC  
 Monday, January 29, 2001 12:27AM

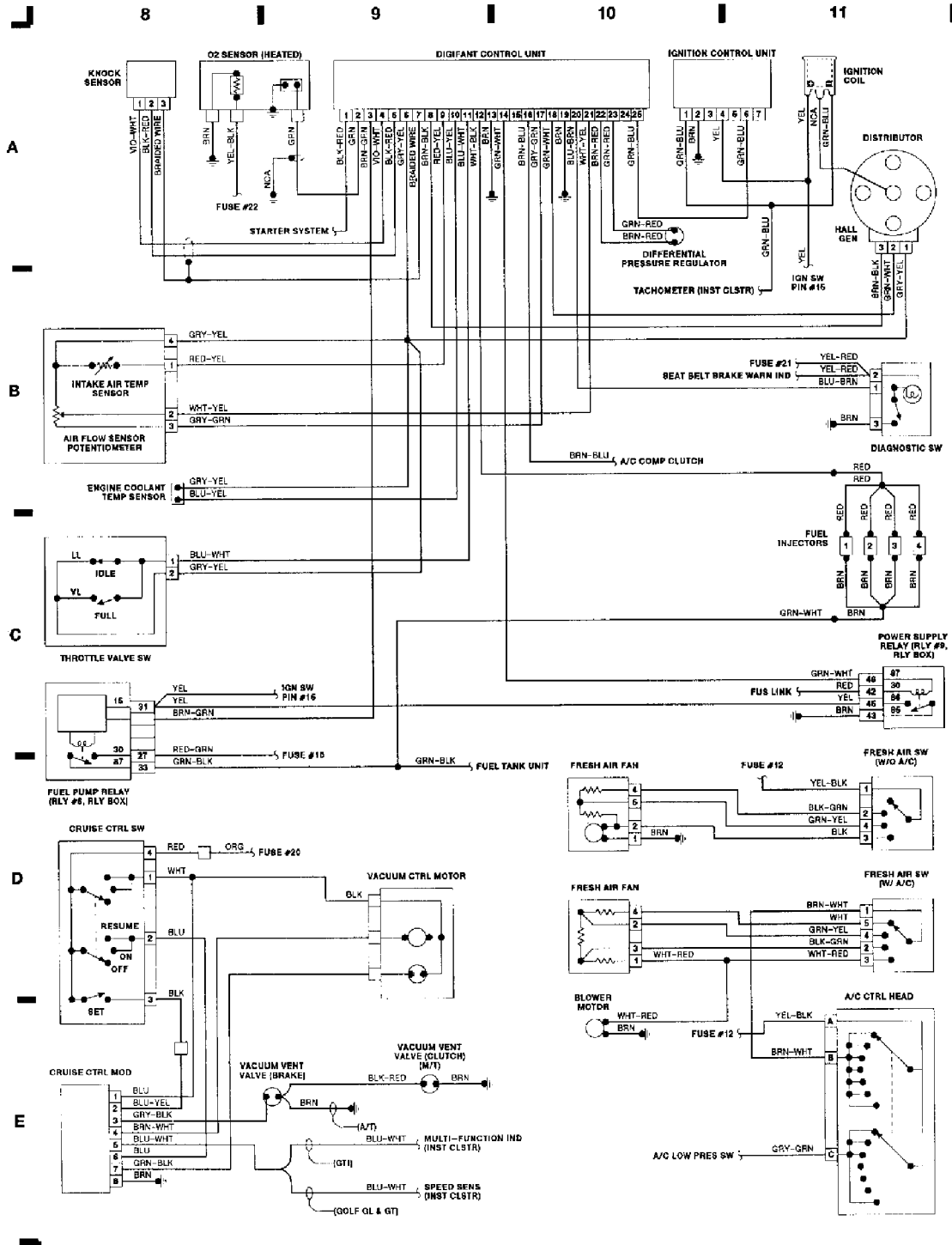

Fig. 3: Computer Engine Control (Golf)

**WIRING DIAGRAMS**  
**Article Text (p. 6)**  
 1988 Volkswagen Golf  
 For <http://volkswagen.msk.ru>  
 Copyright © 1998 Mitchell Repair Information Company, LLC  
 Monday, January 29, 2001 12:27AM

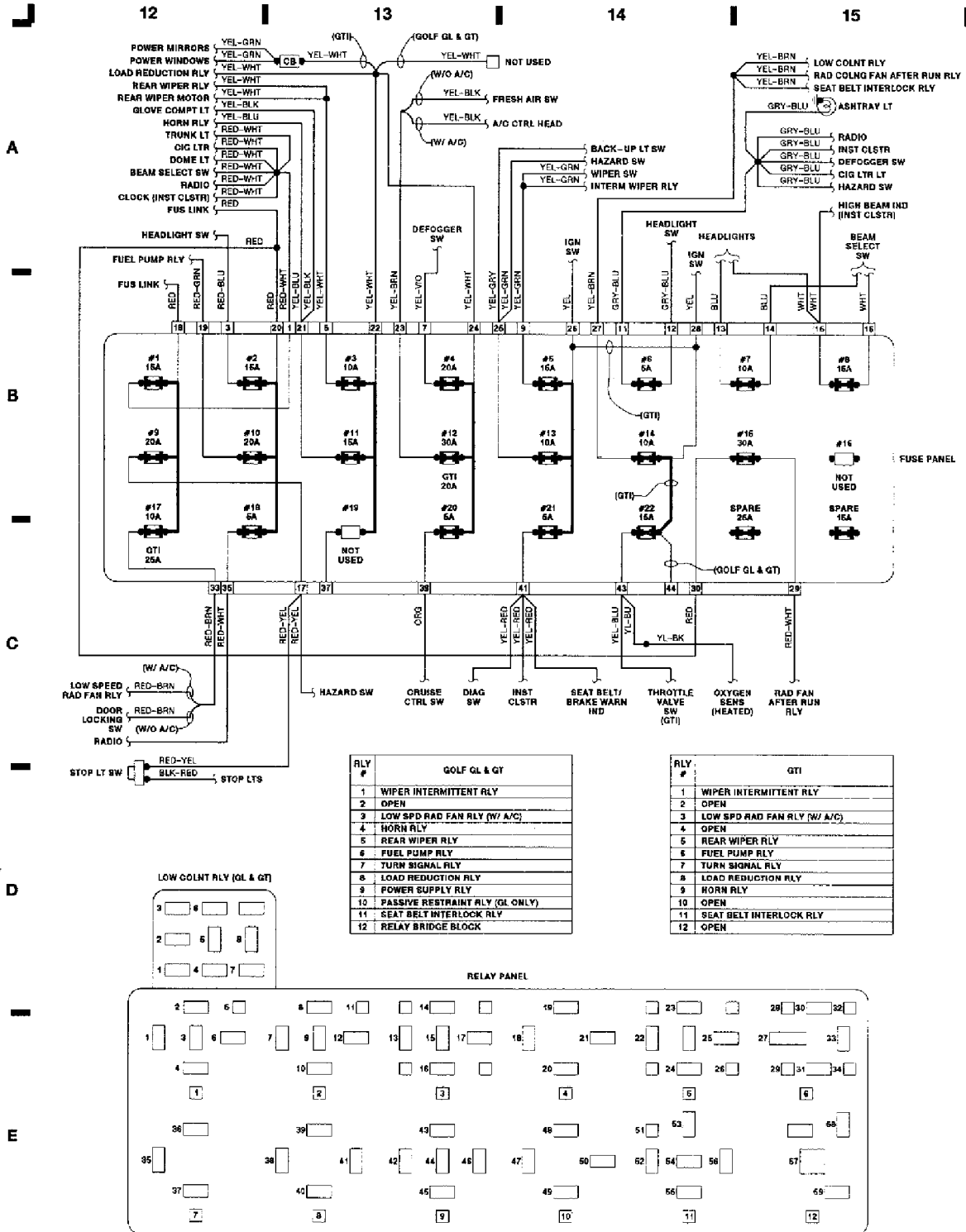

Fig. 4: Fuse Block

**WIRING DIAGRAMS**  
**Article Text (p. 7)**  
 1988 Volkswagen Golf  
 For <http://volkswagen.msk.ru>  
 Copyright © 1998 Mitchell Repair Information Company, LLC  
 Monday, January 29, 2001 12:27AM

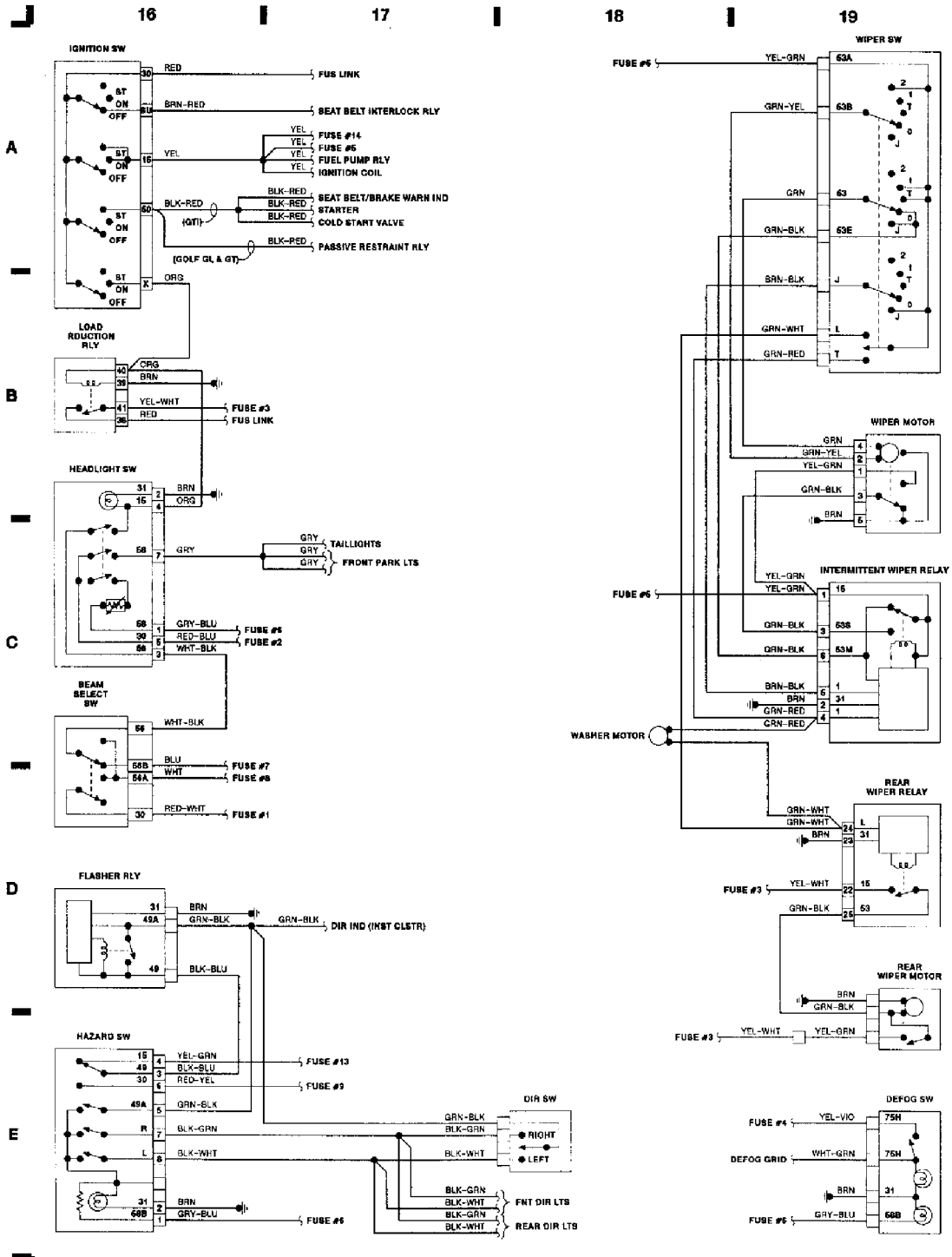

Fig. 5: Steering Column & Instrument Panel Switches

**WIRING DIAGRAMS**  
**Article Text (p. 8)**  
 1988 Volkswagen Golf  
 For <http://volkswagen.msk.ru>  
 Copyright © 1998 Mitchell Repair Information Company, LLC  
 Monday, January 29, 2001 12:27AM

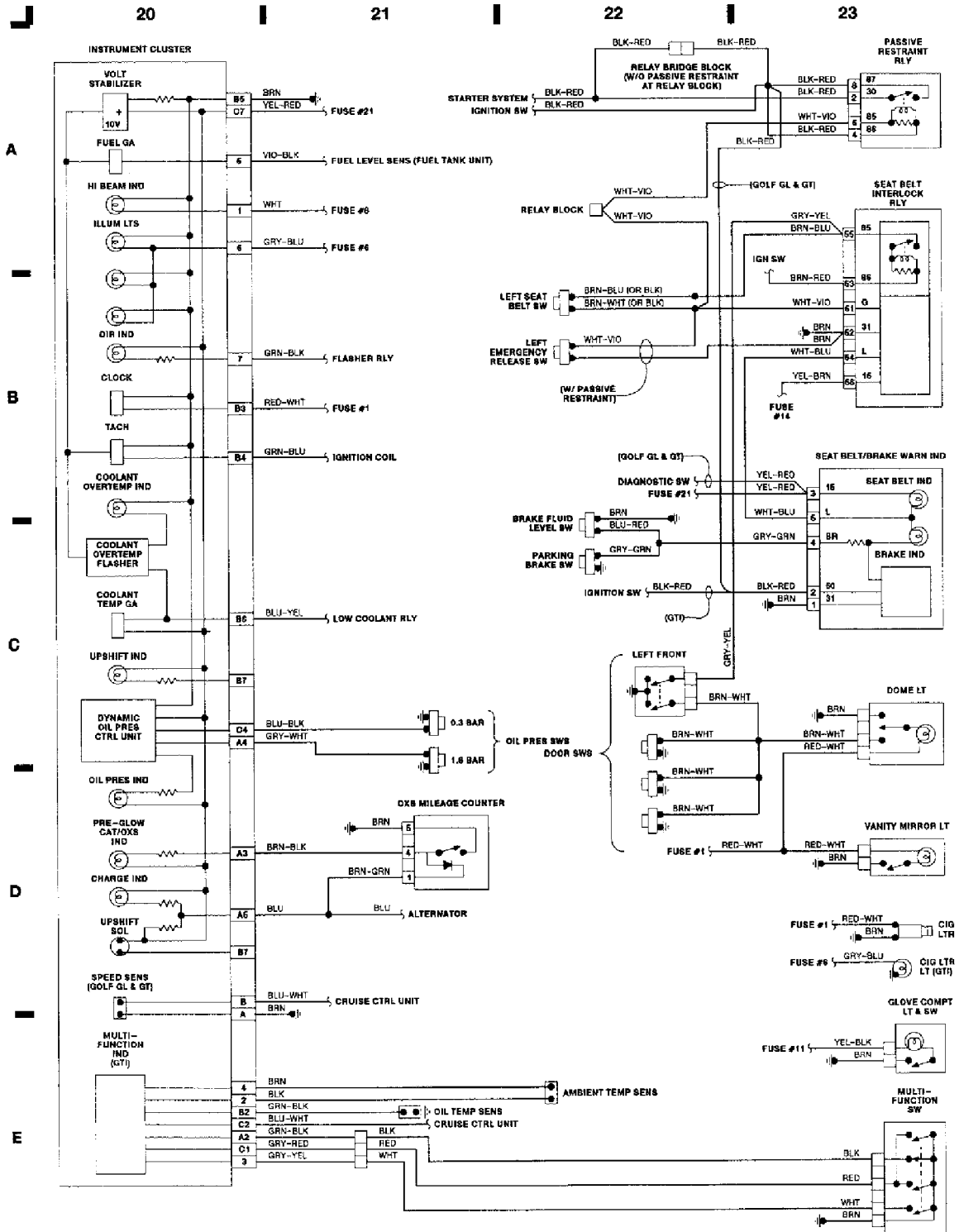

Fig. 6: Instrument Panel



**WIRING DIAGRAMS**  
**Article Text (p. 9)**  
 1988 Volkswagen Golf  
 For <http://volkswagen.msk.ru>  
 Copyright © 1998 Mitchell Repair Information Company, LLC  
 Monday, January 29, 2001 12:27AM

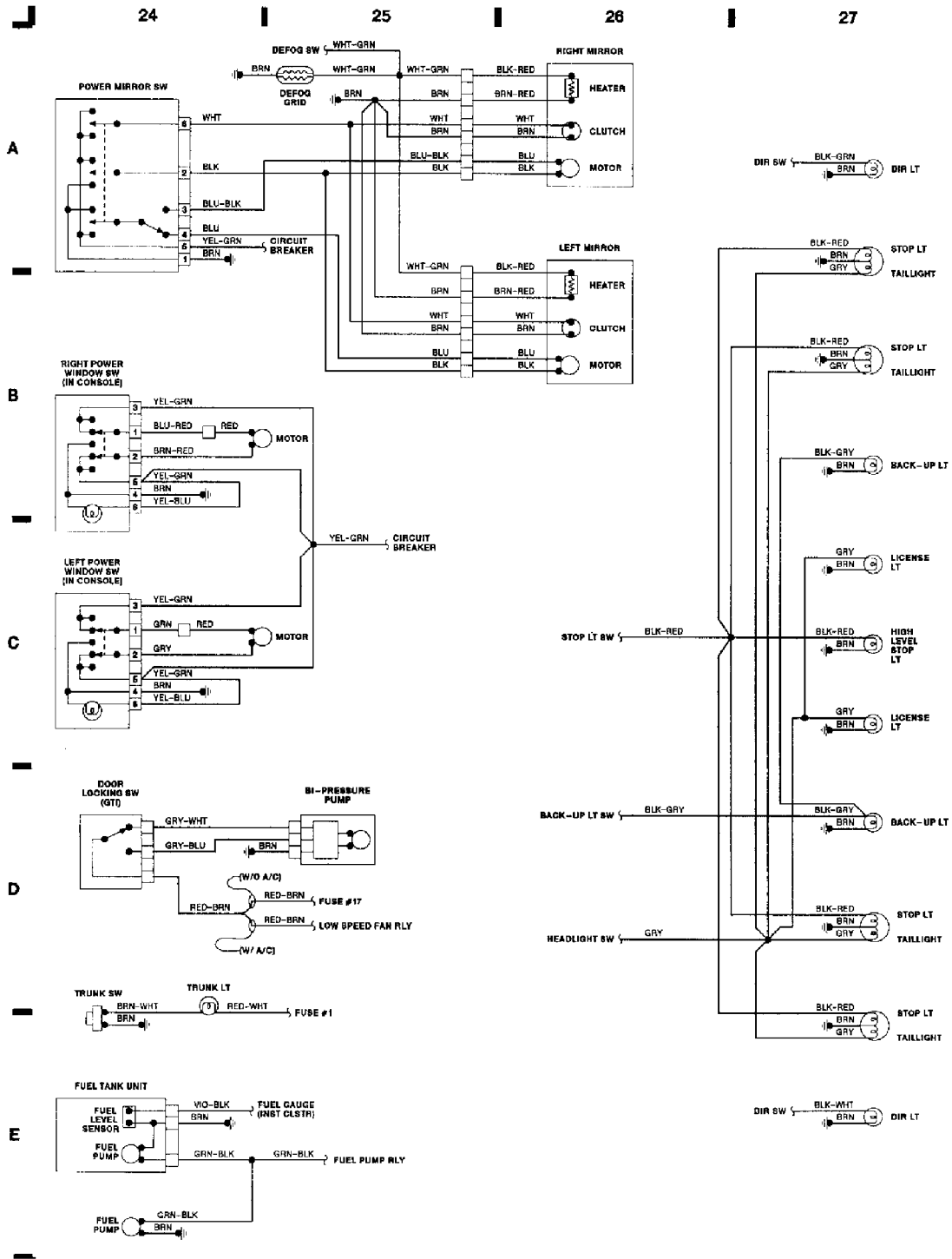

Fig. 7: Passenger Compartment & Taillights

END OF ARTICLE